

REV	ECON	DESCRIPTION	DATE	BY	APP
0	-	RELEASED	11/14/06	D.BIDDLE	LL
1	-	SHORTENED ITEM 11 FROM 25mm TO 28mm ADDED ITEM 13	11/29/06	D.BIDDLE	CT
2	-	MOVED ITEMS 9 & 10 TO THE EXH PORTS	3/28/07	D.BIDDLE	CT
3	-	CHG. CABLE LENGTH FROM 12" TO 7"	1/02/07	VC	LL
4	-	CHG TO NEW VALVE V0D1151-SMD WAS V0D1151-SM	11/17/08	YL	LL
5	-	DELETE K02L06-01S, Q38 WAS Q23, 41.9 WAS 41.9, 23.9 WAS 23.9, 31.9 WAS 31.9 WAS 2. CHANGE DRAWING TEMPLATE	03/04/09	J.V.	LL

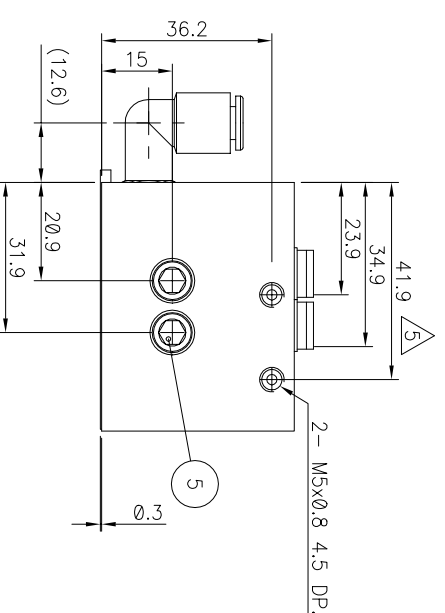
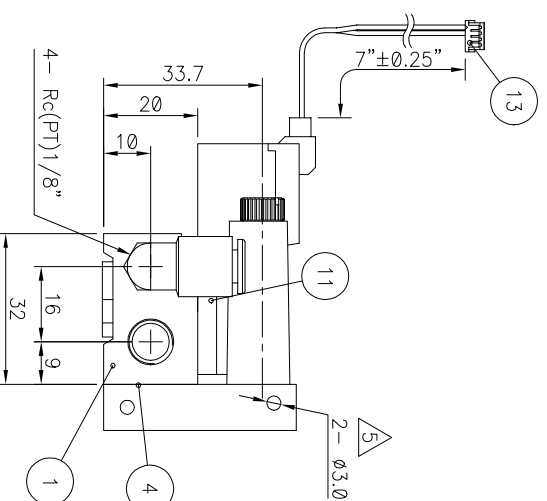
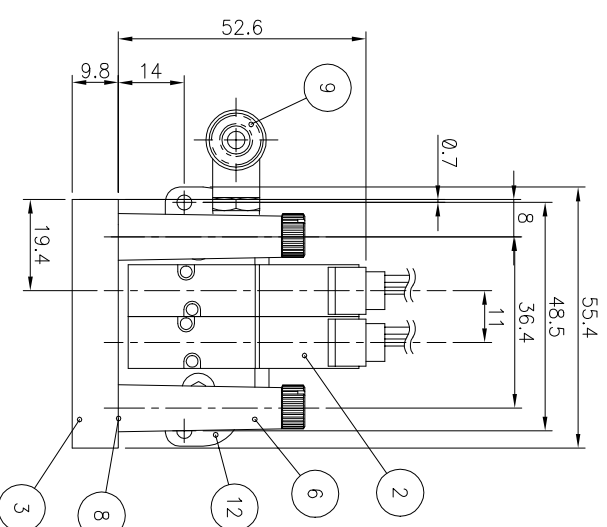
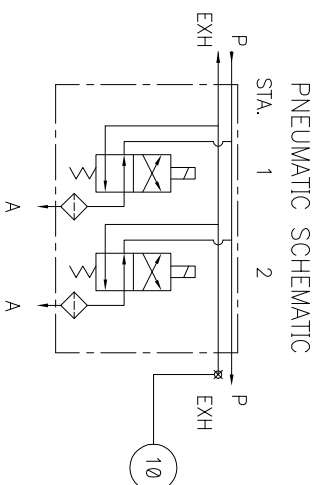

- NOTES: (UNLESS OTHERWISE SPECIFIED)
1. ALL DIMENSIONS ARE IN MILLIMETERS.
 2. TOLERANCES ARE PER JIS B0405, MEDIUM.
 3. ALL () DIMENSIONS ARE FOR REFERENCE USE ONLY.

ITEM No.	PART No.	PART NAME	QTY
13	W44QD15-003-02-DAJ00785	Cable Ass'y	2
12	W44QD15-002-02-DAJ00785	Mounting Bracket	1
11	91292A121	SHCS, M4x20	2
10	R(P1)1/8	Plug, (EXH Port U-side)	1
9	K02L06-01S	Fitting, 6mm Elbow	1
8	ZQ-3-007	Filter Housing Main Seal	2
7			
6	SS3Y1-C02-02-DAJ00894	Modified ZQ1-FCE-AS	2
5	91292A191	M5x8 SHCS, 8-18 SUS.	2
4	9464K14	O-Ring, #009 Viton	2
3	W44QD15-C01-02-DAJ00785	Vacuum Plate	1
2	V0D1151-SM0	Valve, 24 VDC	2
1	W44QD15-02M5	Manifold, 2 Sta.	1

UNITS	SCALE	DATE	DESCRIPTION
MM	1:1	11/14/06	SMC Corporation of America
BY	DATE	DATE	DESCRIPTION
D. BIDDLE	11/15/06	11/14/06	MANIFOLD ASSEMBLY
CHECKED	DATE		
APPROVED	DATE		
LLY	11/15/06		
CD FILE	SIZE		
W44QD15-02-DAJ00785	C		
DRAWING/PART No.			
W44QD15-02-DAJ00785			
REFERENCE NUMBER			
US39285-G			